

Product Specifications



T.E. Berry & Associates

PO Box 9606

Wichita, KS 67277-0606

316 942-4100

info@teberry.com

- Custom Index Tabs
- Multi-Color (4-Color Process) Index Tabs
- Folded Tabs For Perfect Bound Books
- Legal Index Dividers
- Filing System Chart Divider Tabs, Filebacks & DuoTabs
- Polyethylene Tabs
- Synthetic Material Tabs
- Plain Paper Copier Tabs
- Write-On Mylar® Tabs
- Mylar® Tabbed Covers
- Ring Binders & Folders
- Loose Leaf (Binder Inserts)
- Program Releases
- Assembly
- Fulfillment

H.C. Miller Standard Index Specifications & Materials...

	<u>Standard Specs.</u>	<u>Non-Standard Specs.</u>
Paper Stock:	Standard Weight White or Ivory	Heavy Weight White or Ivory Standard Weight Colored Index Standard Weight HCM Buff Index
Size:	11" x 9" (11" x 8 ⁷ / ₈ ") 8 ¹ / ₂ " x 11 ¹ / ₂ " (8 ¹ / ₂ " x 11 ³ / ₈ ") 9" x 11"	8 ¹ / ₂ " x 6", 9" x 6", 10 ⁷ / ₈ " x 9", 11 ¹ / ₂ " x 8 ¹ / ₂ " or 8 ⁷ / ₈ " x 11" (Any size imaginable can be produced)
Tab Ext.:	1/2" or 3/8" Extensions	1/4", 5/8" or 3/4" Extensions
Ink Color:	Black ink only, regular print	Any Colored Ink or Reverse Printed
Body Copy:	Dealer imprint only, 3 lines	Logo / Up to 4-Color Process and full flood ink coverage
Holes:	2 or 3 holes 5/16" in diameter on one binding edge only	More than 3 holes 1/4", 9/32" or 3/8" diameter On two or more binding edges
Banks:	3 to 10 tabs per bank 20 tabs total non-overlapping	More than 10 tabs per bank Overlapping tabs
Mylar®:	Standard Weight 16 colors	Writable Mylar® or Neon Colors
Reinforcing:	9/16" wide	3/4" and 5/8" wide
Collate:	20 tabs or less	More than 20 tabs
Boxing:	Cartons (Inner Cartons-Optional)	Shrink Wrapping or Poly Bagging

H.C. Miller Definitions...

Bank:	One successive row of staggered tabs from first to last position.
Body Copy:	Text or graphics printed other than on tab extensions. (i.e. the "body" of the sheet)
Collate:	Gathering of individual tabs into sequentially ordered sets.
Cut:	Number of tab positions in a bank. (Example: 1/5 cut = 5 tabs of equal size completing one bank)
Mylar® reinforced binding edge:	Strengthened binding edge resulting from application of a Mylar strip to the binding edge on the backside of the sheet.
Mylar® reinforced tab:	Strengthened tab extension resulting from application of a Mylar® coating around tab extension and onto the body of the sheet.
Position:	Sequential location of a specific tab in a bank. (Example: 1 st position of a 1/5 th cut is the first tab in the bank)
Reverse Printing:	Printing of solid background behind tab or body copy with actual copy appearing in color of unprinted paper.
Set:	One each of every individual tab in a job or group.
Shrink Wrapping:	Sealing and heat-shrinking in clear film of individual or multiple tab sets or pieces.
Poly Bag:	Loosely sealed in clear film.
Tab Copy:	Text or graphics printed on tab extensions.
Tab Mylar®:	Clear or colored Mylar® coating around tab extension.

MYLAR® TAB COLOR GUIDE

A custom divider is the most cost effective way to streamline all of your organizational needs while also providing a professional look and feel to your product.

Organize and Enhance your Projects Including:

- Presentations
- Directories
- Reports
- Booklets
- Reference Material
- Catalogs
- Manuals

Customized Index Dividers are Available with:

- Numerous paper stocks, weights, colors and sizes.
- Printed in any color, one sided or two sided.
Print on the tab only or with body copy
- Variety of tab extensions available
- Mylar coated tabs are available in clear or 15 standard colors (displayed on this sheet)

Listed Below are Our Most Commonly Used Papers. These Will Always be Readily Available and Competitively Priced:

Standard Weight Index (White or Ivory)
Heavy Weight Index (White or Ivory)
Paper Plus White Index
10 pt. C-1-S Cover
10 pt. C-2-S Cover

Due to the printing process, actual Mylar® colors may vary slightly from this printed sample. Actual Mylar® samples are available upon request.

*Mylar® is a registered trademark of Dupont.



15 Gauge Poly Divider Colors



048-Gray



062-Gray



078-Yellow



081-Ivory



133-Colonial Blue



1605-Mauve

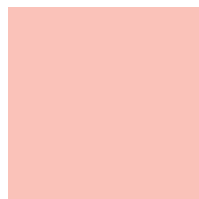

169-Peach



182-Pink



1841-Blue



184-White



325-Teal



359-Maroon



360-Lime



489-Red



517-Gold



562-Beige



608-Green



777-Royal Blue



834-Orange

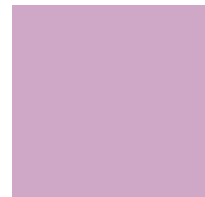

882-Lavender



905-Azure Blue

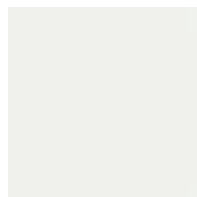

999-Natural



251-Dusty Rose

- Poly colors may vary slightly from this printed example.
- Actual samples available upon request.

Index Sheet Dimensions...

We can create a custom index to fit a carrier of virtually any size. It's important to specify index sheet dimensions in the correct order so we know where to position the tab.

When ordering, specify the dimension of the binding edge first. The illustrations on this page demonstrate the importance of doing so.

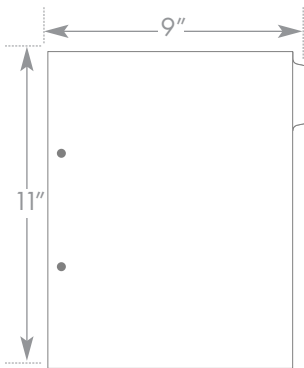

This illustration represents an index measuring 11" x 9", its binding edge runs along the length of the left-hand side of the page – a side measuring 11".

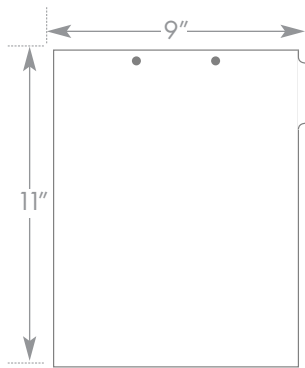

This illustration represents an index that measures 9" x 11", its binding edge runs along the top of the page – a side measuring 9".

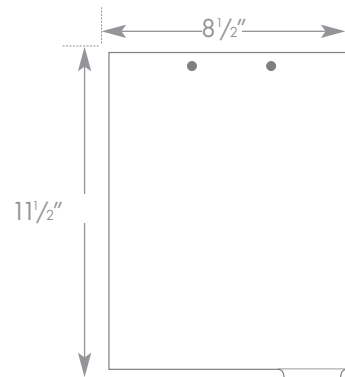

This illustration represents an index that measures 8 1/2" x 11 1/2", its binding edge runs along the top of the page – a side measuring 8 1/2".

Tab Dimensions...

There are two dimensions to a tab – length and extension. When ordering, specify the size for each dimension.

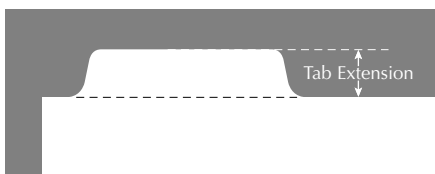

Extension: The extension is the height of the tab, measured from the edge of the index sheet to the top of the tab, as this illustration shows. (Most popular extensions are 3/8" and 1/2" – others available are 1/4", 5/8" and 3/4".)

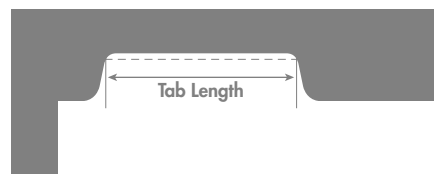

Length: The length is measured along an imaginary line that extends 1/16" down from the top of the tab. (Also referred to as "Cut", ie: 1/5th cut, etc.)

Print on Both the Tab and Index Body...

The type style you choose and the color of ink you print can contribute greatly to the image you desire and the informational impact of your tabs.

Black ink is standard, and it is often used when printing on tabs that will be reinforced with colored Mylar®. We can also match any Pantone color you choose. Tabs can be reinforced with Mylar®, whether they are printed in black or color ink.

Note: Provide us with digital files or print ready art and we can print photographs, illustrations, graphics, logos and even text on the body of the index sheet using one, two or four-color process printing. We will also be happy to create the copy for you.

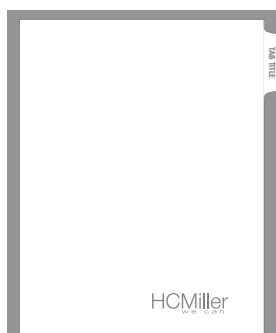
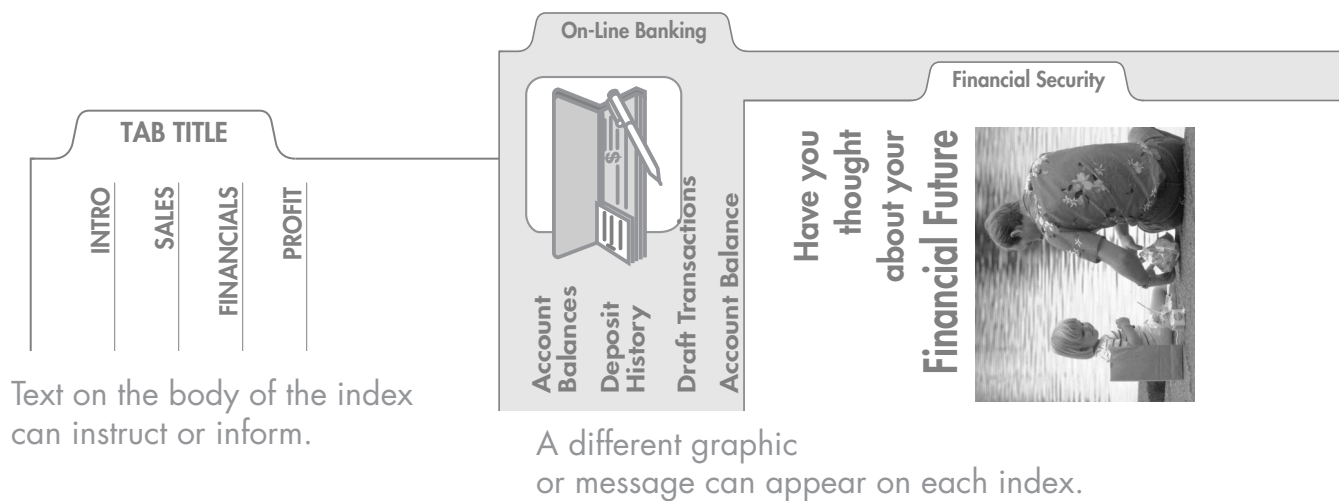

For visual impact...
print a graphic or logo
on the front of the index.



For further impact...
place the logo on the
back of the index.

Custom Tabs...

The pages that follow discuss format, design, layout and banks. Review this section. It provides the variables necessary to customize an indexing system to best suit your needs.

Type Formats...

Tab titles can read in any one of seven ways, as this page illustrates. For the sake of ordering, each format is identified by one of the following letters: A, B, BT, C, I, F & G.

A Most popular style - permits full use of tab length for copy.

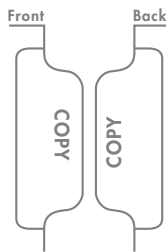

B For single letter or number - for limited copy.

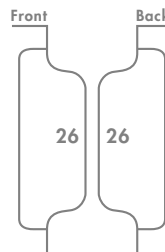

BT For single letter or number; Legal Style Tabs.

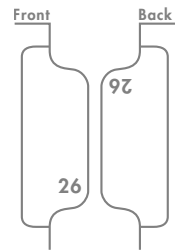

C For stacked copy reading top to bottom.

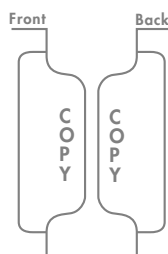

I A combination of style A and B (letters and numbers).

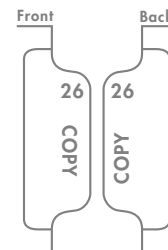

F Hanging Tab - copy reading **left** to right.

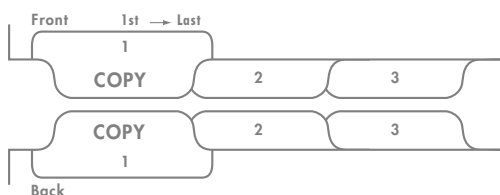

G Hanging Tab - copy reading **right** to left.

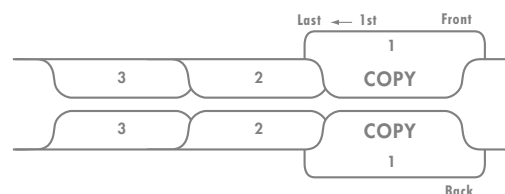

Tab Design

Length...

This is one of two dimensions necessary when specifying tab design. The length is measured along an imaginary line that extends $1/16''$ down from the top of the tab. To determine the length of each tab, you must know the average length of your titles. Tab length can be determined if "cut" is specified, ie: standard $1/5$ cut tabs have a $2''$ tab length when running along the $11''$ edge of the sheet.

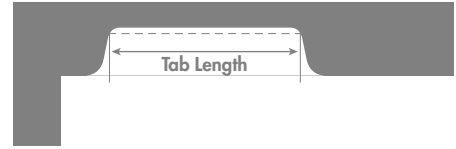

Extension...

This dimension is also needed when specifying tab design. Extension is the height of the tab, measured from the edge of the index sheet to the top of the tab, as this illustration shows. We offer tab extensions in a total of 5 heights, $1/4''$, $3/8''$, $1/2''$, $5/8''$ and $3/4''$. Most popular are $3/8''$ and $1/2''$.

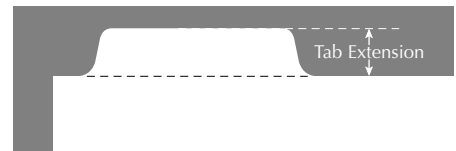

Shoulder...

It is recommended that each tab bank have a $1/2''$ shoulder, which is the distance from the edge of the index sheet to the beginning of the first tab in the bank. This will provide added tear strength by allowing the Mylar® to extend beyond the tab length. We can produce a tab with a smaller shoulder dimension if necessary.



One-Line Titles...

On our standard $1/2''$ tab extensions (meaning height), one-line titles are extremely readable; $3/8''$ tab extensions and non-standard $1/4''$ tab extensions, can also be used for one-line titles.



Multi-Line Titles...

$1/2''$ tab extensions are recommended for titles that require two or three lines.

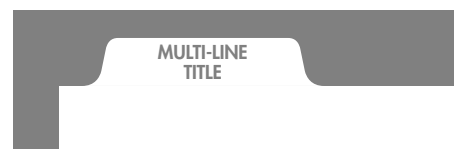

Fileback Dividers

Fileback Dividers make the organization of large file folders simpler and more efficient. Individual fasteners on each divider enable you to add to or delete from any section without disturbing information in other sections. This allows for a more efficient and accurate filing system. Fileback Dividers have several standard features, allowing you to pick and choose to coordinate with your current filing system.

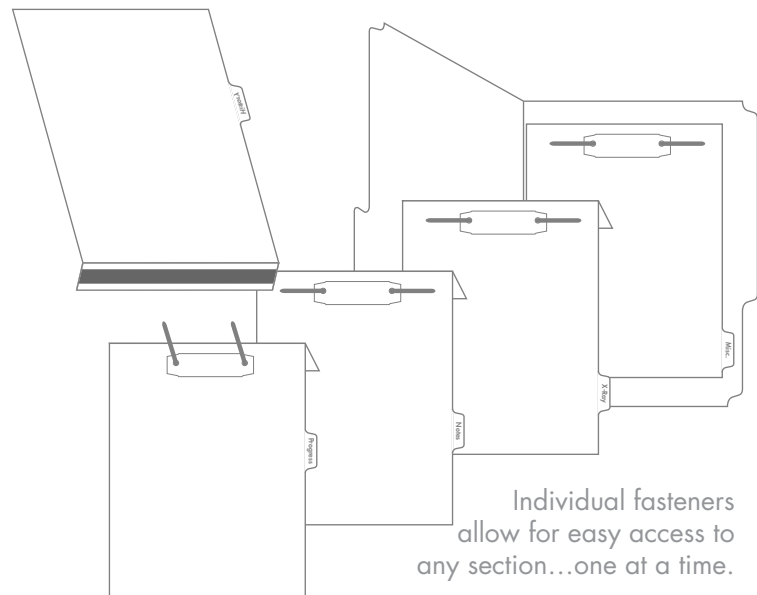

Individual fasteners allow for easy access to any section...one at a time.

Fileback Features...

- Heavy Weight Ivory Index is a high quality, durable and compact paper, making your filing system more space efficient.
- Clear binding edge reinforcing adds additional strength for active file retrieval.
- Tabs can be clear or colored Mylar® film to coordinate with any filing system.
- Tabs can be printed on 1 or 2 sides with black ink.
- 1 fastener and slot hole punches.
- Square sheet corners.
- Scored for easy folding.
- 1 1/2" or 2" metal PermClip® fastener is heat-bonded for durability.

To fit most filing system applications, Fileback Dividers are available in a variety of styles:

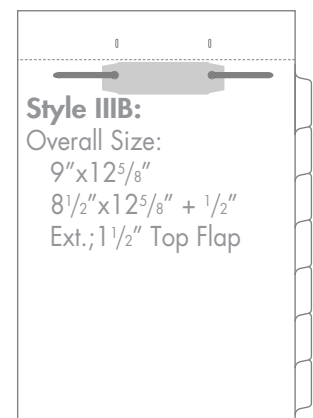
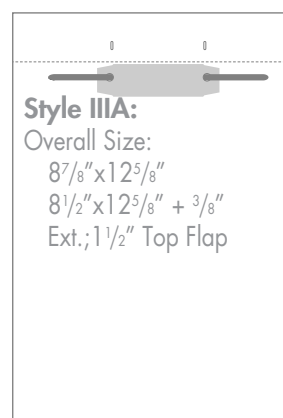
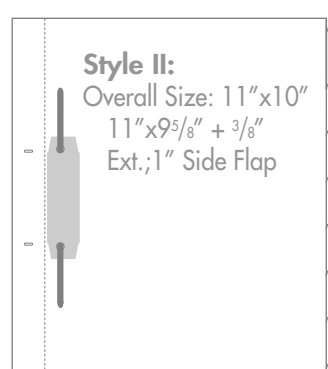
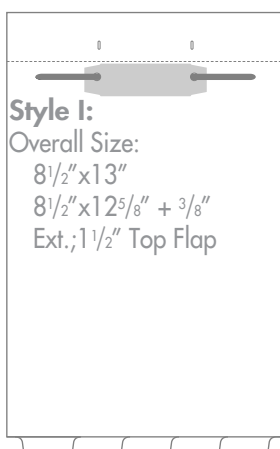

DuoTab Adhesive Fileback

This product was designed for the medical community who currently use standard Filebacks, but find that their folders have become too bulky. DuoTabs, with each divider acting as two tabs*, reduce the bulk and allow for a more manageable system by opening and functioning like a book.

Product Benefits...

- Each DuoTab acts as two tabs
- Creates less bulk in folder
- Quick and easy installation in folder
- Once installed, DuoTabs open and function like a book
- Easy access to each section
- Easy insertion or deletion of material
- Economical, as one sheet acts as two tab dividers

General Specifications...

- High quality, durable Heavy Weight Ivory Index Stock
- Sheet size 11" x 10" including 7/8" adhesive flap and 3/8" tab extension
- 3/4" peel-off adhesive backing for easy and permanent installation
- 1 1/2" or 2" fastener on both sides of sheet
- Tab printing on both sides of sheet

*The DuoTab System of printing allows for the end-user to scan both sides of the tab from the front or the back side. The title for the actual side in use is in bold letters, and the title for the opposite side is printed in smaller type underneath the main title. If this is not the desired format, it is the end-users option for any other printing style.

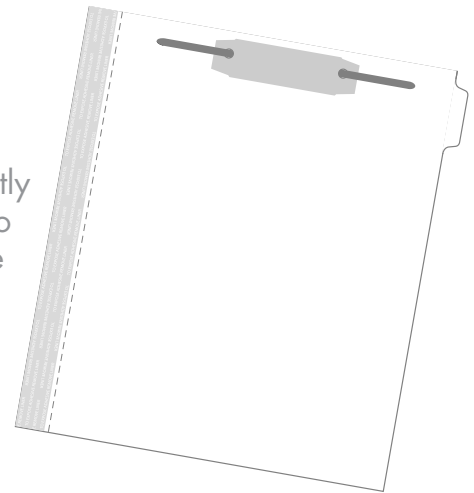

DuoTabs Uninstalled

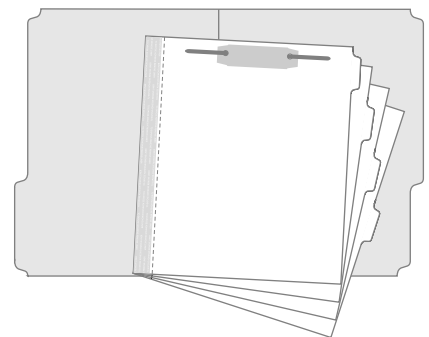

DuoTabs Installed

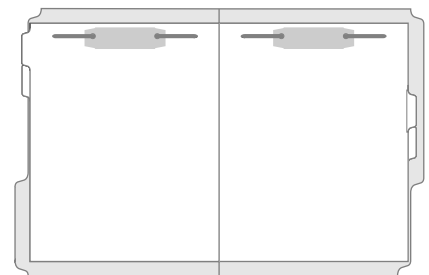

Suggested Format

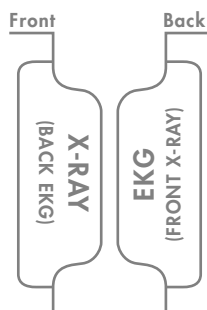

Option A

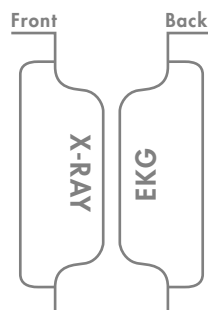

Option B

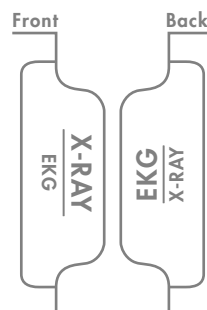

Other

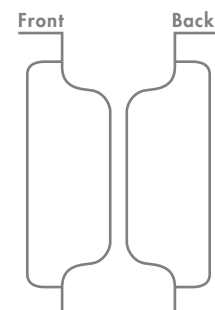



Has a Complete Line of Products to Compliment your Custom Index Tabs

- Folded & Glued Tabs for Perfect Bound Books
- Mylar® Tabbed Folders
- Mylar® Tabbed Covers for Booklets
- Plain Paper Copier Tabs
- Legal Exhibit Tabs
- Custom Vinyl & Poly Ring Binders
- Wire-O Binding
- Complete Manuals
- Custom Personal Organizers
- Assembly
- Fulfillment

T.E. Berry & Associates

PO Box 9606

Wichita, KS 67277-0606

316 942-4100

info@teberry.com